



OAKLANDS FARM SOLAR PARK

Applicant: Oaklands Farm Solar Ltd

Environmental Statement

Appendix 4.5 – Outline Decommissioning Environmental Management Plan
October 2024

Document Ref: EN010122/D5/6.1/Appx 4.5

Version: Deadline 5 - Clean

Planning Act 2008

Infrastructure Planning (Application: Prescribed Forms and
Procedure) Regulations 2009 - 5(2)(a)



Oaklands Farm Solar Park

Decommissioning Environmental Management Plan

Client: BayWa-re
Project/Proposal No: 5037
Version: 4
Date: 2024-10-31





Document Information

Project Name:	Oaklands Farm Solar Park
Document Title:	Decommissioning Environmental Management Plan
Client Name:	BayWa-re
Document Status:	Submission
Author:	Hannah Barnikel
Reviewed:	Emanuele Stella
Approved:	Emanuele Stella
Date:	2024-10-31
Version:	4
Project/Proposal Number:	5037
ITPEnergised Office:	4th Floor, Centrum House, 108-114 Dundas Street, Edinburgh, EH3 5DQ

Revision History

Version	Date	Authored	Reviewed	Approved	Notes
0.5	2024-01-30	H. Barnikel	E. Stella	E. Stella	Final draft
2	2024-08-06	J.Rea / A.Gray	T. Spicer	T. Spicer	Update for Deadline 1
3	2024-09-27	A Gray	T. Spicer	T. Spicer	Update for Deadline 4
4	2024-10-31	A Gray	T. Spicer	T. Spicer	Updated for Deadline 5

© Copyright 2024 ITP Energised. The concepts and information contained in this document are the property of Energised Environments Limited, ITPE Ltd and Xero Energy Limited, trading as ITP Energised. Use or copying of this document in whole or in part without the written permission of ITP Energised companies constitutes an infringement of copyright unless otherwise expressly agreed by contract.

Limitation: This document has been prepared solely for the use of the Client and any party with whom a warranty agreement has been executed, or an assignment has been agreed. No other parties may rely on the contents of this document without written approval from ITP Energised for which a charge may be applicable. ITP Energised accepts no responsibility or liability for the consequences of use of this document for any purpose other than that for which it was commissioned, nor the use of this document by any third party with whom an agreement has not been executed.

The contents of this document are confidential to the intended recipient and may not be disclosed without their express consent. If received in error, please delete it without making or distributing copies. Opinions and information that do not relate to the official business of Energised Environments Limited registered at 4th Floor, Centrum House, 108-114 Dundas Street, Edinburgh, EH3 5DQ or ITPE Ltd., registered at 33 Colston Avenue, Bristol, BS1 4UA, or Xero Energy Limited, registered at 4th Floor, Centrum House, 108-114 Dundas Street, Edinburgh, EH3 5DQ trading as ITP Energised, are not endorsed by the company or companies.



Contents

Document Information	2
Abbreviations	4
1. Introduction	5
1.1 Introduction	5
1.2 Decommissioning Environmental Management Plan	5
2. The site	6
2.2 Infrastructure	6
3. Principles of Decommissioning and Environmental Considerations	6
3.1 Decommissioning Activities	6
3.2 Decommissioning Programme	8
3.3 Deconstruction	8
3.4 Waste Management	9
4. Environmental Mitigation and Management	10
4.2 Responding to Environmental Incidents and Emergencies	15
5. Implementation and Operation	16
6. Monitoring and Reporting	16
Appendix 1 Outline Soil Management plan	18
1. Introduction	18
1.2 Roles and Responsibilities	19
1.3 Soil Resource	20
1.4 Good Practice Mitigation	21
1.5 Stop conditions	22
1.6 Preparation	23
1.7 Soil stripping	24
1.8 Creation of soil stockpiles	27
1.9 Stockpile Maintenance	29



Abbreviations

Term	Definition
BESS	Battery Energy Storage System
DCO	Development Consent Order
DEMP	Decommissioning Environmental Management Plan
DTMP	Decommissioning Traffic Management Plan
OCEMP	Outline Construction Environmental Management Plan
PV	Photovoltaic
PRoW	Public Rights of Way



1. Introduction

1.1 Introduction

- 1.1.1 ITPE has prepared this Outline Decommissioning Environmental Management Plan (ODEMP) on behalf of Oaklands Farm Solar Ltd (hereafter referred to as the 'Applicant') as part of an application for a Development Consent Order (DCO) for the construction, operation and maintenance, and decommissioning of the Oaklands Farm Solar Park (hereafter referred to as the 'Scheme'), comprising the construction and operation of a solar photovoltaic (PV) electricity generating facility with battery energy storage system (BESS) and connection to the grid.
- 1.1.2 Decommissioning comprises the process of removing all site infrastructure associated with the scheme including modules, mounting structures, cabling inverters and transformers, for recycling or disposal in accordance with good practice and market conditions at that time.
- 1.1.3 Upon decommissioning, the above and below ground level physical infrastructure at the Site will be removed, as described in Section 3.3 and the Site returned to the landowner. This will include the areas of agricultural land where the agricultural resource has been maintained (and potentially improved) during operation, and the established habitats. Post-decommissioning, the landowner may return the Site to arable use, although it is assumed that established habitats such as hedgerows and woodland would be retained.
- 1.1.4 These works will be undertaken according to legislation, regulations, and best practice that are current at the time of decommissioning.

1.2 Decommissioning Environmental Management Plan

- 1.2.1 A Decommissioning Environmental Management Plan (DEMP) (or multiple DEMPs) and Decommissioning Traffic Management Plan (DTMP) will be produced and approved for the Scheme prior to the start of the decommissioning phase of the Scheme. This is secured by a Requirement of the DCO.
- 1.2.2 The nature of the decommissioning activities and potential for likely significant effects would be similar to construction. The DEMPs and DTMP will therefore include similar measures to those included in the Outline Construction Environmental Management Plan (OCEMP) and the detailed CEMP, as well as the Construction Traffic Management Plan (CTMP) submitted with the Application, covering issues such as transportation methods, pollution prevention, and noise management.
- 1.2.3 The DEMP(s) will adhere to regulations and guidance at the time, but will include:
 - An overview of the Scheme, decommissioning activities and programme;
 - Prior assessment of potential environmental impacts;
 - Mitigation measures to prevent or reduce potential adverse impacts;



- Monitoring of effectiveness of mitigation measures; and
- Links to other complementary plans and procedures.

1.2.4 The appointed Contractor(s) will be responsible for preparing and working in accordance with the environmental controls documented in the DEMP(s). The overall responsibility for implementation of each DEMP will lie with the appointed Contractor.

2. The site

2.1.1 The Proposed Development is within South Derbyshire District Council local authority area (within Derbyshire County Council) and is close to the boundaries of East Staffordshire and Lichfield Districts.

2.2 Infrastructure

2.2.1 The Proposed Development comprises the construction of the following buildings and infrastructure, the impact of which have been considered in the CEMP:

- Solar PV panels;
- Transformers;
- Switchgear;
- Cabling (high and low voltage)
- Battery Energy Storage system;
- Onsite substation with control building, storage, office and welfare facilities;
- Fencing and security including CCTV;
- Drainage;
- Internal access roads and parking;
- Landscaping and habitat creation areas; and
- Construction laydown areas.

Compound Area

2.2.2 Temporary site infrastructure will consist of, but not be limited to, single and double height portacabins, material storage, and contractor parking.

3. Principles of Decommissioning and Environmental Considerations

3.1 Decommissioning Activities

3.1.1 The land within the Site will be returned to the landowner and to its original use after decommissioning. All above ground infrastructure will be removed.



- 3.1.2 The 2km Temporary Construction Haul Road will be re-instated across Park Farm, Fairfield Farm, and Oaklands Farm, to allow HGVs to travel from Walton Road to the Oaklands Farm area. To leave the Site, HGVs will re-trace the route to exit onto Walton Road. The Temporary Construction Haul Road (including temporary culverts) would be removed following decommissioning, and the land will be restored to its current condition.
- 3.1.3 Foundations and other below ground infrastructure, which are not practicable to remove, will be cut to 1m below the surface to enable future ploughing. Any piles would be removed.
- 3.1.4 The Applicant intends to remove buried cables after decommissioning, though will be led by the planning authority and relevant policy in place at the time of decommissioning. The cables may be left in situ, depending on the method which is likely to have the least environmental impact at the time.
- 3.1.5 If the cables are removed this would be achieved by pulling the cables out of the ducts and the subsequent removal of the ducts themselves, limiting the locations where the surface would need to be disturbed. This same principle will apply to the other high voltage and low voltage cabling throughout the Site to be removed. Any cabling removed will be taken to an appropriate facility for recycling. All waste generated from decommissioning will be given due consideration.
- 3.1.6 Excavations will be backfilled, using appropriate imported soil if required, otherwise with soil sourced on site, using appropriate soil management techniques. Some soil profiling may be required, and the land will be contoured.
- 3.1.7 To restore the land to its pre-construction condition at the end of operation, the soil resource within the Site will need to be managed throughout construction, operation and decommissioning. An Outline Soil Resource Management Plan (SRMP) is included in Appendix 1 and identifies measures to be implemented to:
- ensure the protection and conservation of soil resources; and,
 - maintain the physical properties of the soils through best practice; and provide on-site reference on the management of the soil resource for site operators undertaking the works.
- 3.1.8 The soil will have undergone approximately 40 years of recovery through less intensive farming, such as being left fallow or used for sheep grazing and is therefore expected to be of the same or better quality as it is at present.
- 3.1.9 Where localised soil compaction occurs from the presence of structures or the weight of mobile machinery used through operation and decommissioning, management measures are identified to alleviate compaction (e.g. through ploughing), to maintain soil structure and enable reinstatement of the land (including best and most versatile land) to its original use and ALC grade.
- 3.1.10 At the point of decommissioning, drainage and flood risk will be considered based on legislation and best practice at the time.



- 3.1.11 The Applicant will leave any equipment which is not removed in a safe condition, free from hazardous structures and hazardous materials. Equipment will be left electrically safe and in compliance with all relevant statutory obligations.
- 3.1.12 Where soil has been disturbed and physical restoration is taking place, the soil should be replaced to the full profile identified in the auger point information of the Agricultural Land Classification (ALC) reports. The full profile down to 120cm should be regarded as the soil resource.
- 3.1.13 The majority of restoration involves only shallow, topsoil restoration, as described in the oSMP. The Applicant is committed to ensuring that the land quality following decommissioning is the same as the land quality prior to construction.
- 3.1.14 It is not expected that soil will be imported for restoration. If any topsoil or subsoil does not need to be imported, this material shall: a) be stored separately in a designated area; b) be agreed as suitable prior to placement by an appropriately qualified soils surveyor; and c) be free of objects greater than 15cm in any dimension which would be likely to cause obstruction to cultivations.

3.2 Decommissioning Programme

- 3.2.1 Decommissioning is expected to take between 12 and 24 months and will be undertaken in phases.
- 3.2.2 The Scheme is assessed in the Environmental Statement as being decommissioned after approximately 40 years of operation, with decommissioning assumed to be not earlier than 2067.
- 3.2.3 More details on the decommissioning phasing will be provided within the final DEMP in consultation with the local planning authorities, prior to decommissioning commencing.

3.3 Deconstruction

3.3.1 Process

- 3.3.2 Materials installed as part of the Consented Development, including below and above ground infrastructure will be removed as part of the decommissioning process. Foundations and other below ground infrastructure, which are not practicable to remove, will be cut to 1m below the surface to enable future ploughing. Any piles would be removed. The materials will either be recycled offsite, disposed of offsite, or reused around the landowner's landholding.
- 3.3.3 Contamination and mitigation measures (as appropriate) will be considered (e.g., for any equipment to be left in situ) and any waste generated will be managed in accordance with best practice at the time of decommissioning.



3.4 Waste Management

3.4.1 Waste electrical and electronic equipment (WEEE)

3.4.2 The waste management options for the PV modules and batteries will follow the life cycle stages and decommissioning schedules will provide options for recovery opportunities for reuse and recycle. The focus of the waste management principles will be the collection and delivery of waste electrical and electronic equipment (WEEE) to operators of approved collection facilities. Re-use good practice is to ensure WEEE is treated with due care. The final DEMP will set out the roles and responsibilities of construction workers for safe management of the decommissioning phase. Data management and reporting will be undertaken to ensure that there is a record of WEEE collections and transport to track where items are sent and the number or tonnage of those items.

3.4.3 Table 1 summarises the currently available and intended methods of disposal of the principal site infrastructure materials. No materials are deemed hazardous in their intact form.

Table 1. Method of Disposal

Infrastructure	Principle Materials	Method of Disposal
Solar Modules	Glass Silicon Photovoltaic Cells Plastics Aluminium Copper Adhesives and Sealants	Off-site recycling Currently approximately 80% of silicon solar modules are recyclable.
Supporting Frames	Zinc Galvanised Steel	Off-site recycling
Electrical Cabling and Electrical Connectors	Copper Steel Plastics Ceramics	Off-site deconstruction Once separated, materials will be either recycled or disposed of.
Ducts	uPVC Plastic	Off-site recycling
Inverters and Transformers	Copper Steel Aluminium Ceramics Plastics Electrical Components	Off-site deconstruction Once separated, materials will be either recycled or disposed of.



Infrastructure	Principle Materials	Method of Disposal
Battery Storage Units	Lithium-ion (Li-ion) batteries Steel Copper Plastic Epoxies	At the end of the equipment life, the equipment will be returned to the supplier for recycling, repurposing, or disposal.
Fencing and Gates	Zinc Galvanised Steel Wire Mesh Wood	Off-site recycling, (with the potential for continued use of the fencing elsewhere on the estate.)
Hardstanding, foundations and access tracks	Aggregates	On and off-site reuse
	Concrete	Off-site recycling (crushed for reuse as hardcore)
CCTV Cameras	Plastics Glass Electrical Components	Off-site deconstruction Once separated, materials will be either recycled or disposed of.

3.4.4 A Site Waste Management Plan should be included in the final DEMP and will:

- Identify personnel with waste management responsibilities;
- Describe the proposed works;
- Outline opportunities for waste minimisation/reuse in line with the requirements of the waste hierarchy;
- Review any outline decisions taken to minimise the amount of waste produced on site;
- Provide a forecast of waste types and estimated arisings and outline how they will be managed.

4. Environmental Mitigation and Management

4.1.1 A summary of potential mitigation and management measures during decommissioning is provided in Table 2. The nature of the decommissioning activities and potential for likely significant effects would be similar to construction, and therefore the DEMP(s)/DTMP will include similar measures to those included in the CEMP(s) and CTMP.

Table 2. Potential Mitigation and Management Measures



Mitigation and Management Measure	Effect
<p>Climate Change Standards of good practice for climate change will be followed to minimise greenhouse gas emissions from activities and vehicles.</p> <p>Suitable measures will be implemented during decommissioning to manage risk of flooding and extreme weather events due to climate change and ensure safety of staff. An emergency response plan would be prepared and implemented, and a designated flood warden appointed.</p>	<p>Minimise greenhouse gas emissions from activities and vehicles during decommissioning.</p> <p>Increase resilience to flood risk during decommissioning and ensure site personnel are protected.</p>
<p>Ecology Standard management measures will be implemented to prevent pollution incidents, minimise effects on ecology from noise and vibration, prevent and minimise dust creation and air pollution. Precautionary working method statements would be produced, controlled and implemented.</p> <p>A Species Protection Plan will be provide in the DEMP in accordance with contemporary legislation at the time of writing and will:</p> <ul style="list-style-type: none"> • Identify personnel with protected species responsibilities including a suitably qualified ecologist as an appointed Ecological Clerk of Works; • Provide a plan identifying the suitable habitat for protected species within the site; • Outline the decommissioning activities that have the potential to affect protected species; • Provide the results of pre-commencement species surveys • Set out the measures to protect habitats during construction • Set out the measures to protect species during construction • Set out how the protection measures will be monitored <p>Nesting and Breeding Birds Measures will be implemented in order to mitigate for impacts to nesting and breeding birds. Where reasonably practicable, vegetation clearance works would be undertaken outside the bird breeding season (March-August).</p> <p>Reptiles and Amphibians</p>	<p>To minimise the loss of existing habitats and minimise impact on biodiversity within the Order limits.</p>



Mitigation and Management Measure	Effect
<p>Reasonable avoidance measures would be used during habitat clearance suitable for reptiles, encouraging animals to move away from affected areas to adjacent suitable habitat.</p> <p>Badgers Implementation of an appropriate buffer of up to 30m around a badger sett during decommissioning works.</p> <p>Bats Implementation of an appropriate buffer of 25m around trees with bat roost potential during decommissioning works</p> <p>Invasive Species Pre-decommissioning surveys will be undertaken to provide an update on the presence and location of any invasive species. If any future infestations of invasive nonnative species are identified prior to any decommissioning works, exclusion zones will be established around them, and the Ecological Clerk of Works (ECoW) contacted for advice as required. To minimise the loss of existing habitats and minimise impact on biodiversity within the Order limits.</p>	
<p>Noise and Vibration Standards of good practice for noise and vibration will be followed to minimise noise and vibration impacts from activities and vehicles. Working hours will run from 07:00 to 19:00 Monday to Saturday. A noise monitoring scheme will be developed and agreed with appropriate stakeholders prior to commencement of decommissioning works.</p>	<p>Minimise noise and vibration from activities and vehicles during decommissioning and ensure ensuring levels of noise and vibration do not exceed relevant guidance.</p>
<p>Water Relevant Good Practice Guidance (GPPs) and Pollution Prevention Guidance (PPGs), as well as additional good practice guidance for the water environment including British Standards and key CIRIA documents, will be followed for the water environment and flood risk during decommissioning. Best practice measures will be incorporated for the safe storage of materials, including appropriate containment measures, bunding, drip trays installed as part of plant and machinery used and water suppression will be used to suppress fugitive dust emissions. A water quality management plan will be developed as part of the DEMP and will detail management measures including any water quality monitoring to be undertaken. If decommissioning site runoff is treated on site, a Water Discharge Activity Permit will be</p>	<p>Minimise the risk of flooding and pollution to waterbodies.</p>



Mitigation and Management Measure	Effect
<p>acquired as necessary. The Water Quality Management Plan will:</p> <ul style="list-style-type: none"> • Identify personnel responsible for protecting water quality and preventing silt from entering water courses • Provide a map showing the location of all watercourses in and within 50m of the site boundary • Describe the proposed works that have the potential to affect water quality and generate silt; • Provide a full schedule of mitigation measures to be implemented at specific phases and locations of the development; • Demarked an 8m offset from all watercourses • Provide a programme for regular monitoring of watercourses • Set out a remedial action plan should a water quality or silt deposition event occur 	
<p>Agriculture and Soils A Soil Resource Management Plan (SRMP) will be prepared in accordance with the Outline SRMP setting out measures to manage the reinstatement of any stored soils and minimising soil disturbance and soil compaction when extracting supports for the solar PV panels. It will be particularly important to avoid causing soil compaction during the decommissioning phase. To reduce ground pressure tracked plant and machinery or plant and machinery equipped with low ground pressure tyres should be used in the decommissioning. In areas where soil may need to be reinstated e.g. where buildings are demolished, or tracks taken up guidance in Defra’s Construction Code of Practice for the Sustainable Use of Soils on Construction Sites (PB13298) or reference appropriate at the time may provide useful guidance.</p>	<p>Protect and conserve soil resources on site and maintain the physical properties of the soils through best practice for reinstatement.</p>
<p>Transport A DTMP will be prepared to manage traffic associated with decommissioning and will include measures to minimise the impact of construction traffic on surrounding roads, including disruption and risk of traffic accidents along local access roads and along Public Rights of Way (PRoW). Measures will include: - Restricting movement of Heavy Goods Vehicles (HGVs) to certain routes and times of day. - A monitoring</p>	<p>Minimise the impact of construction traffic on surrounding roads, including disruption and risk of traffic accidents along local access roads and along Public Rights of Way (PRoW).</p>



Mitigation and Management Measure	Effect
<p>system and Delivery Management System to record the route of HGVs to and from the Order limits and regulate their arrival times to ensure compliance. - Encouraging alternative travel arrangements for site personnel, including car sharing and shuttle bus services to reduce the volume of vehicle trips required.</p> <p>A Public Rights of Way Management Plan will be produced that will:</p> <ul style="list-style-type: none"> • Identify personnel responsible for safeguarding users of the Cross Britain Way and public safety; • Provide a clear plan showing the location of the PRow and where it will be affected • Detail the working hours of the decommissioning activities • Set out a schedule of measures to employed to safeguard users of the PRow for the entire decommissioning period 	
<p>Air Quality</p> <p>Standards of good practice for air quality, as set out in the Institute of Air Quality Management (IAQM) 'Guidance on the Assessment of Dust from Demolition and Construction', or relevant guidance will be followed during decommissioning to minimise for dust from activities and vehicles. A dust management plan, as part of the DEMP will detail any dust monitoring required prior to and during decommissioning, including any relevant baseline dust monitoring to be undertaken before activities commence.</p>	<p>Minimise dust emissions from activities and vehicles.</p>
<p>Landscape and Visual</p> <p>All works affecting trees should be undertaken in accordance with best practice tree protection measures.</p> <p>Lighting</p> <p>Standard good practice measures will be followed with regards to safe site lighting during decommissioning. For example, motion detection security lighting will be used to avoid the use of permanent lighting therefore reducing light spill to boundary features.</p>	<p>Protect trees and conserve landscape and biodiversity features. Minimise visual impacts</p>
<p>Waste</p> <p>Suitable measures for the sustainable use of resources and waste management will be implemented during decommissioning. The contractor will seek to use material</p>	<p>Minimising unnecessary use of resources and waste production during decommissioning.</p>



Mitigation and Management Measure	Effect
<p>resources efficiently, reduce waste at source, ensuring segregation of waste to reduce waste that requires final disposal to landfill and apply the principles of the waste hierarchy. Infrastructure such as PV panels and battery storage units will be removed and recycled as far as practical and in accordance with legislation and guidance applicable at the time, or if more suitable at the time, sold for refurbishment and reuse. A Site Waste Management Plan setting out how measures to manage the disposal of waste from the Order limits, will be prepared in accordance with relevant legislative and policy requirements at the time of decommissioning.</p>	
<p>Ground Conditions Standards of good practice for ground conditions, will be followed during decommissioning to prevent, contain and remediate contamination.</p>	<p>Minimise the risk of contamination decommissioning.</p>
<p>Accidents and Disasters The risk of major accidents and disasters during decommissioning will be addressed through relevant risk assessments and management plans prior to undertaking the works. All works will be undertaken in accordance with relevant Health and Safety legislation and guidance with relevant emergency details publicised and communicated to all site personnel.</p> <p>Unauthorised access has the potential to result in fire if persons are intent on damage/sabotage. To prevent unauthorised access, during all stages of the Proposed Development the Site will be suitably secure to protect from criminal damage. This includes secure fencing and gated entrances, CCTV and remote monitoring, and lighting of critical areas (secured within the CEMP, OEMP and DEMP). On site staff during all phases will also act as a deterrent to criminal activity.</p>	<p>Minimising the risk of major accidents and disasters and protecting the site and personnel.</p>

4.2 Responding to Environmental Incidents and Emergencies

4.2.1 The Contractor(s) will designate an Environmental Manager who will be responsible for the implementation of the DEMP(s). This individual will be notified, as soon as it is safe to do so following an environmental incident and emergency. A reporting procedure will be agreed with the local authorities and any other statutory bodies such as Environment Agency. Staff will be informed of this process



and made aware that it is everyone's responsibility to call the emergency services, should this be needed.

5. Implementation and Operation

5.1.1 The DEMP(s) will set out all roles, responsibilities and actions required in respect of implementation of the mitigation measures, including:

- An organogram showing team roles, names and responsibilities;
- Training requirements for relevant personnel on environmental topics;
- Information on-site briefings and toolbox talks that will be used to equip relevant staff with the necessary level of knowledge to follow environmental control procedures;
- Measures to advise employees of changing circumstances as work progresses;
- Communication methods;
- Document control;
- Monitoring, inspections and audits of site operations; and,
- Environmental emergency procedures.

6. Monitoring and Reporting

6.1.1 Environmental monitoring of the Scheme and its impacts will be undertaken throughout the decommissioning phase. Monitoring requirements will be detailed in the DEMP(s).

6.1.2 The Environmental Manager will observe site activities and report any deviations from the DEMP(s) in a logbook, along with the action taken and general conditions at the time. The Applicant will be informed by the contractor(s) of any deviations from the DEMP(s) as soon as possible following identification of such issues. The Environmental Manager would also act as day-to-day contact with relevant local authorities and other regulatory agencies such as the Environment Agency.

6.1.3 During decommissioning, the Environmental Manager will conduct regular walkover inspections to ensure all requirements of the DEMP(s) are being met. Action from these surveys will be documented on an Environmental Action Schedule for actioning.

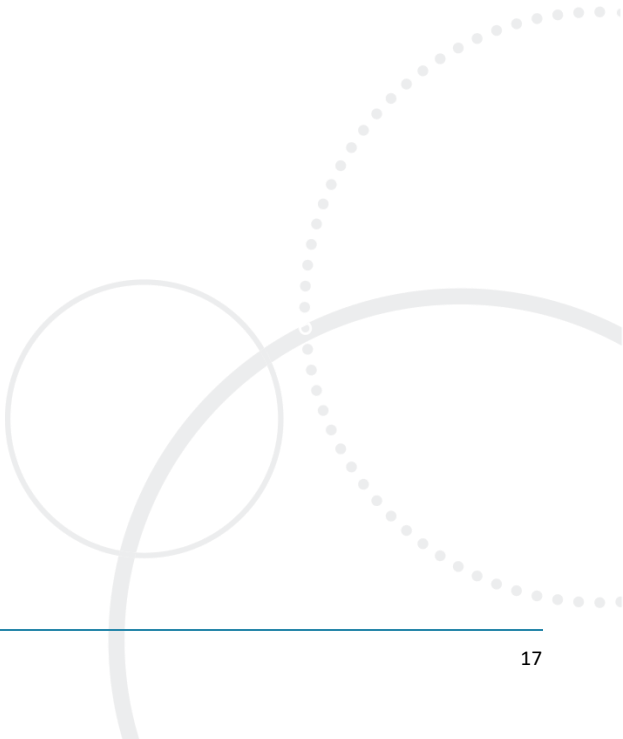



Appendix 1 Outline Soil Management plan

1. Introduction

- 1.1 The Outline Soil Management Plan (OSMP) sets out principles and procedures for good practice (embedded mitigation measures) and bespoke mitigation measures in soil handling, storage and reinstatement to be used for the Proposed Development. This outline plan describes the principles that the Principal Contractor will follow to minimise adverse effects on the nature and quality of the soil.
- 1.2 To secure effective delivery of the OSMP, the Contractor must implement it through site-specific soil management method statements (or similar) for the construction phase. The works must also be monitored to audit compliance with the OSMP (and location-specific construction method statements); and to allow ongoing advice on soil handling to be provided. The OSMP is based upon guidance such as the Department for Environment, Food and Rural Affairs (Defra's) Construction Code of Practice for the Sustainable Use of Soils on Construction Sites, and the Institute of Quarrying (2021) Good Practice Guide for Handling Soils in Mineral Workings.
- 1.3 The OSMP assumes that all mitigation measures pertaining to protected species and other environmental issues are in place, such that the soil stripping, storage and reinstatement operations can proceed.
- 1.4 The OSMP is considered to be a 'live document' to be updated as further information becomes available. The OSMP will be revised prior to commencement of construction operations to consider the site-specific soils data collated by the appointed specialist agricultural land drainage consultant as part of the agricultural drainage design works.
- 1.5 The Site has been the subject of two detailed Agricultural Land Classification (ALC) surveys. These set the existing land quality. The Applicant commits to ensuring



that land quality is not adversely affected, and where moved and restored soils are brought back to the pre-existing land quality, as recorded in the ALC reports.

- 1.6 The Applicant commits to the repair of land drains or the installation of new land drains where removal of solar panel mounts and/or the removal of underground electrical cabling results in damage or disturbance to existing land drains and where an unacceptable surface water issue occurs as a result. Once established, the drainage on-site will be monitored for up to 5 years, and drainage measures altered or improved as necessary.
- 1.7 Following decommissioning, soils will be restored to the pre-construction ALC grade, without exception. A programme of monitoring for up to 5 years will be set out, to ensure that the correct ALC criteria have been reached (on land restored to agriculture) and the habitats created are in a suitable condition. Depending on the land-use, agricultural activities, site-specific conditions and site-specific construction activities, the aftercare may include treatments such as: cultivation (e.g. subsoiling), installation of underdrainage, seeding, liming, and/or fertilising.

2. Roles and Responsibilities

2.1 Overview

- 2.1.1 The effective implementation of the OSMP requires that roles and responsibilities are clearly defined and understood. Specific job titles, roles and responsibilities will be defined by the Contractor in the location specific construction management plans; however, the roles and responsibilities will be similar to those described below, as described in the Construction Environmental Management Plan (CEMP).

2.2 Construction Manager

- 2.2.1 Responsible to the Project Manager for:

- Determining and sourcing the plant and equipment to be used;
- Ensuring that working areas, services and stockpiles are clearly marked;
- Ensuring that records are maintained; and
- Ensuring that staff receive appropriate training regarding soil handling issues such as stop conditions and soil testing requirements.

2.3 Site Foreman

- 2.3.1 Responsible to the Construction Manager for:



- Implementing the site-specific construction soil management method statements to manage soil handling and storage on site to ensure the sustainable use of the soil resource;
- Ensuring daily records of weather conditions, stoppages and soil plasticity (moisture) testing are made and kept;
- Ensuring that works are carried out safely, under correct conditions and in compliance with wider environmental requirements; and
- Ensuring that the protection of services is maintained during the soil handling works.
- Ensuring that the services of an appropriately qualified soil surveyor are utilised, as necessary, to advise on the suitability of soils being moved.

2.4 Safety Advisor

2.4.1 The safety adviser is responsible to the Project Manager for:

- Ensuring the plant operators have the relevant training and certification.

3. Soil Resource

3.1.1 The erodibility of a soil (susceptibility to damage and loss) influences the level of mitigation required to protect it and the measures to be put in place through the OSMP and site-specific construction method statements.

3.2 Soils with low risk of erosion

3.2.1 Good practice (embedded mitigation) measures following those recommended in Defra's Construction Code of Practice for the Sustainable Use of Soils on Construction Sites and the Institute of Quarrying's Good Practice Guide for Handling Soils in Mineral Workings (2021) , will provide appropriate protection to these soils as they are generally more resistant to damage and loss.

3.3 Soils with moderate risk of erosion

3.3.1 Good practice (embedded mitigation) measures will mostly provide appropriate protection to these soils, however damage is likely to occur if worked in less than ideal conditions, for example when the soils are wet. Therefore, on a location by location basis, depending upon factors such as physical soil properties and local topography, bespoke mitigation measures may be required. The soils should be given appropriate consideration because of their importance for agricultural production.

3.4 Soils with high risk of erosion

3.4.1 Development on those soils should be avoided if possible, however where this is not possible, they require special consideration and careful planning of



construction methods, i.e. bespoke mitigation measures, in order to preserve their structure and function.

4. Good Practice Mitigation

4.1 General principles of soil handling

4.1.1 The main threats to soil resources at construction sites are trafficking of vehicles/plant and incorrect handling, which can cause damage to soil structure through compaction and smearing (both effects are sometimes referred to as deformation). These effects compromise the ability of the soil to perform its functions, such as providing adequate amounts of water, air and nutrients to plant roots. The risk of compaction and smearing increases with soil wetness. To minimise the risk of damage to soil structure, the following main rules must be observed during all soil handling tasks:

- Soil tests for suitability for being handled should be carried out daily in accordance with the guidance in the Institute of Quarrying's Good Practice Guide to Handling Soils (2021) involving examination and consistency tests.
- No trafficking/driving of vehicles/plant or materials storage to occur outside designated areas.
- No trafficking/driving of vehicles/plant on reinstated soil (topsoil or subsoil).
- Only direct movement of soil from donor to receptor areas (no triple handling and/or ad hoc storage).
- No soil handling to be carried out when the soil moisture content is above the lower plastic limit.
- Soils should only be moved under the driest practicable conditions and this must take account of prevailing weather conditions. (see rainfall "stop" criteria in paragraph 3.5.2).
- No mixing of topsoil with subsoil, or of soil with other materials.
- Soil only to be stored in designated soil storage areas.
- Plant and machinery only work when ground or soil surface conditions enable their maximum operating efficiency.
- All plant and machinery must always be maintained in a safe and efficient working condition.
- Daily records of operations undertaken, and site and soil conditions should be maintained (see section 5 for the summary of monitoring and record keeping schedule).
- Low ground pressure (LGP models) and tracked vehicles should be used where possible. This will greatly minimise the extent and/or intensity of the soil loosening required after restoration. Consequently, it will reduce the costs and potential delays due to the need for additional soil cultivation.



- 4.1.2 The location-specific methods statements (or similar) must be defined based on the results of detailed site-specific soil survey.
- 4.1.3 As a general rule the soil is least likely to be suitable for being handled between the months of October and March inclusive. In this period, the advice of an appropriately experienced soil surveyor to advise on the suitability of the soil for being trafficked and handled, should be taken. This will include inspections of the site and will involve the examination and consistency tests set out in the Institute of Quarrying's Good Practice Guide to Handling Soils (2021).
- 4.1.4 A detailed phasing plan including soils should be developed pre-commencement to phase the works so that any movement of the heaviest soils within the site should be targeted to take place, so far as possible, in the driest months of the year (May to September).
- 4.1.5 The survey results should be used to specify in detail:
- The 'before' statement of physical characteristic of the soil to be disturbed;
 - where bespoke mitigation measures are required, and what these bespoke measure entail;
 - the depth and properties of topsoil; and
 - the depth of subsoil and presence of any distinct soil horizons.

4.2 Stop conditions

4.2.1 Adverse weather

- 4.2.2 In certain weather conditions, the handling of topsoil and subsoil must be effectively managed to prevent damage. The examination and consistency tests set out in the Institute of Quarrying's Good Practice Guide to Handling Soils (2021) should be applied. Topsoil and subsoil handling must cease applying the following criteria:
- in drizzle and/or intermittent light rain, handling can continue for up to four hours unless the soils are already in a plastic state (see paragraph 1.5.6);
 - if there is heavy rain (e.g. heavy showers, slow moving depressions), handling must stop immediately;
 - soil shall not be handled or trafficked over/driven on immediately after a heavy rainfall (or snow/hail) in a waterlogged condition, or when there are standing pools of water on the soil surface.
 - If the works are interrupted by a rainfall event, soil stripping should be suspended; and where the soil profile has already been disturbed, the works should be completed to the base level in that location.
- 4.2.3 Additionally, soil should not be handled or trafficked over/driven on when the ground is frozen or covered by snow.



4.2.4 Supplementary Note 4 on Page 35 onward of the Institute of Quarrying's Good Practice Guide to Handling Soils (2021) should be followed.

4.2.5 The above criteria should be clearly understood by all personnel.

4.2.6 Soil conditions

4.2.7 Irrespective of the weather, soils should not be handled when in a plastic state (when moisture content exceeds their lower plastic limit); and as a general rule should be dry when handled.

4.2.8 If the soil is excavated and placed in stockpiles when wet (above the plastic limit), they are easily compacted by the machinery handling them, or by the weight of the soil above it in the stockpile. As well as this damage to soil structure, when soils within a stockpile are compacted, the core of the stockpile remains anaerobic throughout the storage period. This damage results in the soil being very difficult to handle and re-spread at the time of reinstatement (i.e. it will not be in a friable state and will not break down into a suitable tilth). In this case, in order to achieve the required standard of restoration, a period of drying and appropriate additional cultivation is required (to repair soil structure and re-aerate the soil) to ensure the soil is acceptable for planting. The costs of these unplanned operations, and consequent delays to the programme of works, could be substantially, if not several times, greater than the costs of ensuring that the soil stripping and stockpiling operations are carried out in optimum conditions and making allowances for delays due to bad weather.

4.2.9 For arable land, the period where the soil conditions will generally be the driest typically occur in the summer following the spring crop harvest, when the plant evapotranspiration will have dried the soil.

4.2.10 Once the placement of soils into each stockpile has been completed, rainfall and soil moisture conditions are of lesser importance, providing they do not lead to significant environmental impacts, such as erosion and discharges of sediment laden water from the stockpiles to drainage ditches and other watercourses.

4.3 Preparation

4.3.1 Mark and signpost the undisturbed areas where no construction activities or vehicle trafficking over/driving on is to take place per detailed works plans and construction method statements (to be prepared post-consent by the Contractor). Any trees, hedgerows or valuable habitats which are to be retained should be marked out with barrier tape; and subsequently protected and managed.

4.3.2 As per the requirements of detailed works plans and construction method statements (to be prepared post-consent by the Contractor), any underground services crossing the area of soil stripping area are to be surveyed and their depth and position clearly marked to ensure they are not impacted by the stripping works. After stripping, to ensure the integrity of the service infrastructure is maintained, the service location may require fencing off; or if the area over the service is to be trafficked additional protection or mitigation may be required.



- 4.3.3 Mark soil storage areas for different types of topsoil, subsoil and mineral substrate. In some locations, the excavated soil profile may contain more than one distinct subsoil horizon (layer). Where this occurs, due to the different properties of the different horizons, they must be excavated and stored separately.
- 4.3.4 At designated crossings (specified in the location-specific construction method statements) a 2 m width of topsoil will be left unstripped at either side of the ditch/watercourse to act as a filter for water run-off.
- 4.3.5 To reduce the likelihood of anaerobic conditions developing within the topsoil stockpile prior to the soil strip commencing the topsoil surface should either be bare, under stubble, or have only short surface vegetation. To achieve short surface vegetation (for example in areas of permanent pasture or under a hay crop), if not already done so prior to the land being handed over to the Project, the area should be mown or strimmed. Cuttings must not be added to or mixed with the stripped soil, as the presence of excessive amounts of plant material in the stockpile will be detrimental to its quality due to its putrefaction (rotting) in anaerobic conditions. Alternatively, the vegetation may be killed off by application of a suitable, Environment Agency approved, non-residual herbicide applied not less than two weeks prior to commencement of soil stripping operations at the location. Herbicide may only be used with the consent of the landowner and subject to the conditions/restrictions within the contract.
- 4.3.6 The site staff must be competent to perform the tasks as they have the potential to cause an environmental impact. The training and awareness is to be ensured according to the procedures and tools described in the Construction Environmental Management Plan (CEMP). Carry out toolbox talks with all personnel involved in the groundworks communicating the principles of good practice in soil management and its goals.

4.4 Soil stripping

- 4.4.1 Topsoil can be stored on either topsoil (of the same type) or on subsoil. Subsoil can ONLY be stored on subsoil and therefore the topsoil must be stripped from subsoil storage areas in advance of subsoil stripping.
- 4.4.2 The stripping method should follow one of the suggested methods as described in Sheet A of the Institute of Quarrying's Good Practice Guide to Handling Soils (2021) should be followed . When preparing the trenches for installing the cables and during the preparation of the working areas, the excavated sub soil will be stored on the opposite margin of the working area to the top soil,
- 4.4.3 Where soils are to be stored away from the excavation area, two excavators and one transport vehicle will be required for soil stripping operations. One excavator will be required to undertake the soil stripping and the other to form the soil stockpiles. The excavator undertaking the soil stripping should be fitted with a toothed bucket, except in the areas of known archaeological significance or high archaeological potential (see above), where a toothless bucket should be employed to prevent damage to the underlying archaeology. The method, if correctly carried



out, should avoid severe compaction as soil trafficking is minimised. The concept of this method is shown in Plate 1 and Plate 2. It is not foreseen on this project that it will be necessary to store topsoil or subsoil away from the immediate area where it has been excavated.

- 4.4.4 The size of the earthmoving plant to be used should be tailored to the size of the area to be stripped and the space available within the working area. The use of a long reach excavator, which will minimise the need for movement across the soil surface, and the use of tracked vehicles or vehicles with a low ground bearing pressure is recommended to further reduce soil compaction.

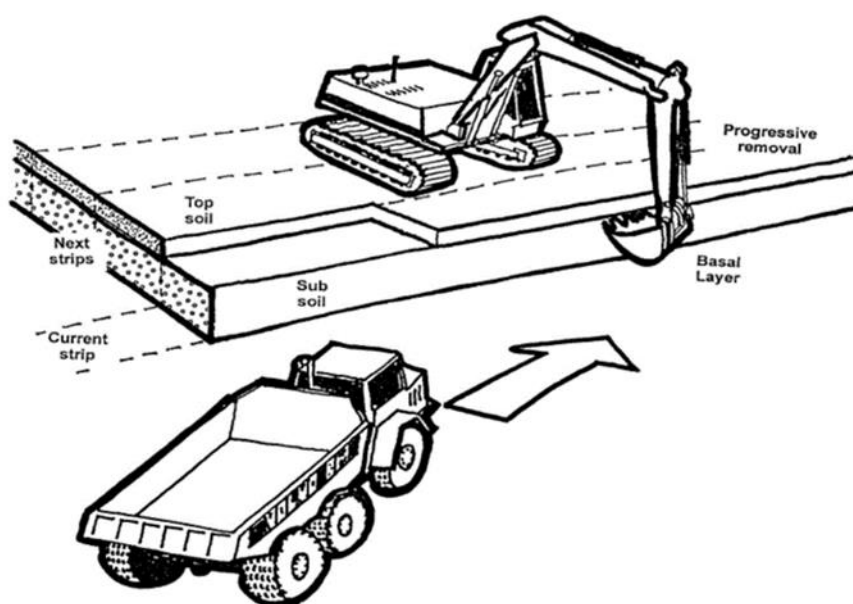

***Plate 1: Stripping with excavators and dump trucks: removal of topsoil from a strip.
Reproduced from Sheet A of the Institute of Quarrying's Good Practice Guide to
Handling Soils (2021)***

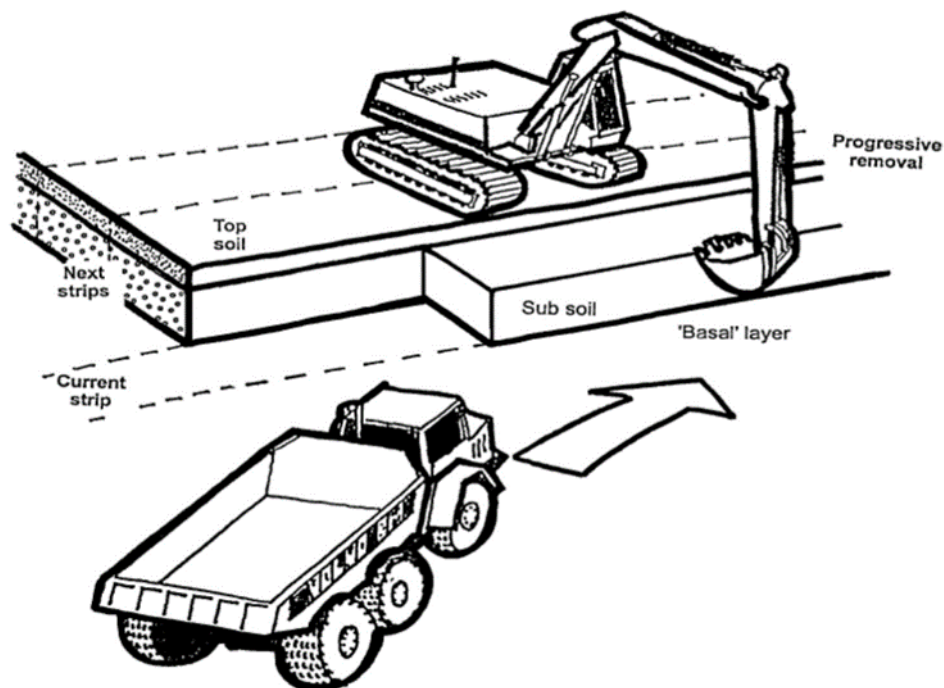

Plate 2: Stripping with excavators and dump trucks: removal of subsoil from a strip.
Reproduced from Sheet A of the Institute of Quarrying's Good Practice Guide to Handling Soils (2021)

- 4.4.5 Prior to commencement of soil stripping, the width of each strip must be determined. Strip width is determined by the length of the excavator boom less the stand-off to operate; typically, 3 to 4 m.
- 4.4.6 The strip width should make full use of the reach of the excavator. This will maximise the time the excavator can remain at a fixed location, before moving further along the strip; minimising the number of locations subject to the weight of standing plant.
- 4.4.7 The depth of the topsoil strip is to be determined on a 'location by location' basis. During the strip, the excavator should stand on the surface of the topsoil, digging the topsoil to the required depth and forming the stockpile or loading it into the transport vehicle (dump truck). Following topsoil removal, the subsoil can be excavated. Topsoil should be recovered to the full width of the strip without contamination with the subsoil. The boundary between the topsoil and subsoil is usually very clearly visible through a change in colour (the topsoil being much darker due to greater organic matter content). However, this may not always be the case, as often the topsoil gradually transitions into subsoil, and their colours are similar. Therefore, the depth of the topsoil to be stripped must be determined by measuring the depth from the surface (excluding any vegetation) using the soil survey data as described above. Topsoil should be restored to the original depth to ensure that there is no diminution in the agricultural land quality of the Site identified in the ALC surveys.



4.4.8 The key points to minimise soil compaction and maximise its readiness for reuse are:

- The operations of the vehicles (excavators and dumper trucks, if relevant) on the topsoil should be minimised.
- Plant and machinery are to only work when ground conditions enable their maximum efficiency.
- Soils should only be handled when dry
- Stop conditions as set out in section 3.5 must be observed.
- Protect the subsoil from ponding of water by diverting water inflow away from it.
- Do not work when there is standing water on the topsoil or subsoil surface.

4.5 Creation of soil stockpiles

4.5.1 Correct storage/stockpiling will maintain soil quality and minimise damage to soil structure and soil biota. This ensures that the soil will readily recover once re-spread, promoting timely and effective restoration. Stockpiled soil must not be vulnerable to compaction or erosion; must not cause pollution to surrounding watercourses; and must not increase flood risk to the surrounding area.

4.5.2 Potential soil erosion and water pollution can be minimised through a number of good practice measures, including, but not limited to; the avoidance of trafficking over/driving on the soil stockpiles, the seeding of stockpiles; and the use of intermittent spaces in the stockpiles.

4.5.3 Soil should not be stacked closer than 5 m from a watercourse or ditch. Gaps shall be left where necessary to allow for surface water drainage and avoid the catchment (ponding) of water behind stockpiles.

4.5.4 Ecologically important soils, for example woodland or hedgerow soils, must be stripped and stored separately to ensure the seedbank is retained and not mixed with neighbouring agricultural soils. These stockpiles must be appropriately marked out and clearly signed to ensure that they are easily identifiable at restoration, as specified in the location-specific construction method statements.

4.5.5 Generally, topsoil stockpiles should not exceed 3 m in height and subsoil stockpiles should not exceed 5 m in height. However, if the soil to be stockpiled is dry (below the plastic limit) formation of higher stockpiles may be permissible, as the soil is likely to remain dry in the core of the stockpile for the entire storage period. However, the appropriateness of higher stockpiles will need to be established on a location by location basis.

4.5.6 Stockpiles are to be formed by 'loose-tipping' followed by 'shaping' to form a level surface on top of the pile and uniform gradients down the sides. During 'forming', the top and sides should be smoothed so that they can shed water, ensuring that the entry of the water to the stockpile is limited and that the stored soil remains

dry; and helping prevent erosion and ponding. This is achieved by dragging the bottom of the excavator bucket along the stockpile surface.

- 4.5.7 The natural angle of repose of a soil, and hence the maximum gradient (slope) of the stockpile sides, depends upon its texture and moisture content. The maximum achievable slope angle is 40° however, shallower angles are often more appropriate.
- 4.5.8 For soil that is to be stored longer than six months the slope angle should not exceed 25° to enable grass to be seeded and managed.
- 4.5.9 The topsoil and subsoil stockpiles along cable trenches are to be formed using one back-acting/360° excavator as they will be too close to the excavation to require transport in a separate vehicle.

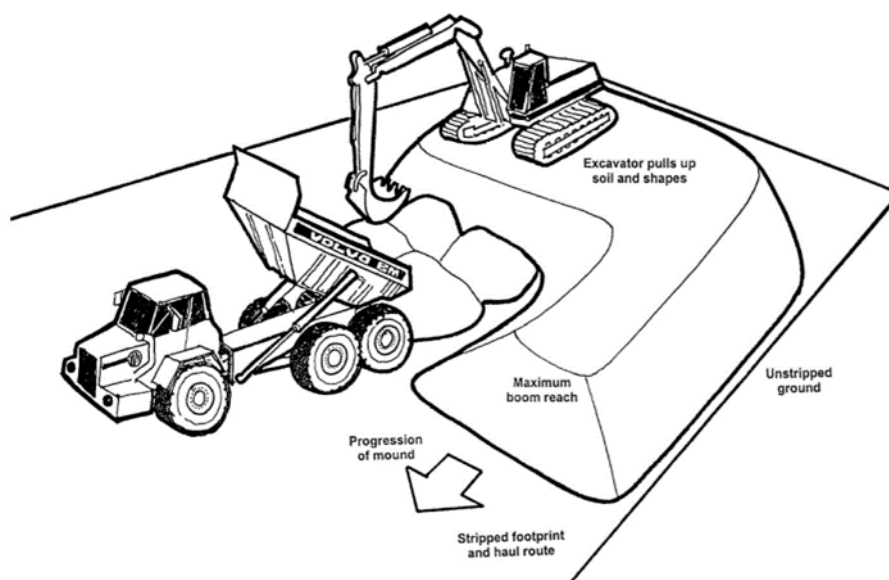

Plate 3: Soil storage mound construction with excavators and dump trucks. Reproduced from the Good Practice Guide for Handling Soil (Institute of Quarrying, 2021)

- 4.5.10 If transport is required, follow the method described in the Good Practice Guide for Handling Soil (Institute of Quarrying, 2021) Building Soil Storage Mounds with Excavators and Dump Trucks illustrated in Plate 3. A dump truck should transfer soil material between the stripping and storage areas. The dump truck should enter the storage area, reverse and back-tip the soil load starting at the furthest end of the stockpile (see Plate 3). Repeat the process of tipping the soil against the forming stockpile and without the wheels traversing onto previously tipped material. For this operation, a second back-acting/360° excavator will be required with the boom reach allowing it to form a stock pile of up to 4 m while standing on it.
- 4.5.11 Use of a front-loading machine to form the stockpile is possible if this is a Contractor's preference. If this alternative is chosen; the tipped soil must not be travelled or pushed with a bulldozer blade. It must be lifted by the front-loading machine and tipped into place to form a desired stockpile height. The top and side surfaces of the stockpile must be formed in order to shed the rainwater.



4.6 Stockpile Maintenance

- 4.6.1 In cases where soil will be stored for a period of more than six months, the stockpiles should be seeded with appropriate low maintenance grass/clover mixture (for example EG22c Emorsgate Seed, or similar: to be agreed with landowner and subject to the conditions/restrictions within the contract; to protect the soil against erosion, minimise soil nutrient loss, and maintain soil biological activity. Appropriate seeding will also help prevent colonisation of the stockpile by nuisance weeds that could spread seed onto adjacent land.
- 4.6.2 In the period where vegetative cover on the stockpiles is establishing, where required during dry weather, the stockpiles will be sprayed with water to prevent wind erosion (generation of dust) and to ensure that the seeds establish.
- 4.6.3 The stockpile vegetation cover is to be managed (by spraying, mowing or stripping as appropriate and as defined in location-specific construction method statements, or similar), to prevent the spread of seeds from the stockpile onto adjacent land.
- 4.6.4 The condition of the stockpiles is to be regularly monitored. If rainwater gathers on the stockpile surface or in areas directly adjacent to them, drainage pathways to soakaway area away from the stockpile should be provided.

4.6.5 Stockpile Records

- 4.6.6 The locations and footprints of each stockpile should be accurately recorded on a plan of appropriate scale. Marker post should be provided in locations which have been surveyed and recorded.
- 4.6.7 The approximate volume of each stockpile should be recorded, along with details of the type of soil stored.

4.6.8 Drainage

- 4.6.9 Prior to soil stripping, where required, pre-construction drainage will be installed per specification provided by a specialist drainage contractor. This drainage is designed to prevent water entering the working area.
- 4.6.10 Gaps shall be left between soil stockpiles where necessary to allow for surface water drainage and avoid the catchment (ponding) of water behind stockpiles. In certain areas (as defined in location-specific construction method statements or similar) 'grips' may be dug across the working area at predetermined locations to prevent erosion and prevent ponding against stockpiles. Appropriate measures such as stones silt traps and silt fencing will be employed as required.



ITPEnergised is a leading international consultancy delivering expert energy, environmental, engineering, technical advisory and asset management services; facilitating the transition to net zero.

Visit the ITP Energised group offices in:

Bristol, London, Edinburgh, Glasgow, Buenos Aires, Madrid, Delhi, Beijing, Canberra, Auckland

Sectors:

Onshore Renewables & Storage | Offshore Wind & Marine Renewables | Oil & Gas Transition
Property & Urban Regeneration | Corporate, Industrial & Manufacturing

